

# Industrial Clutch Products

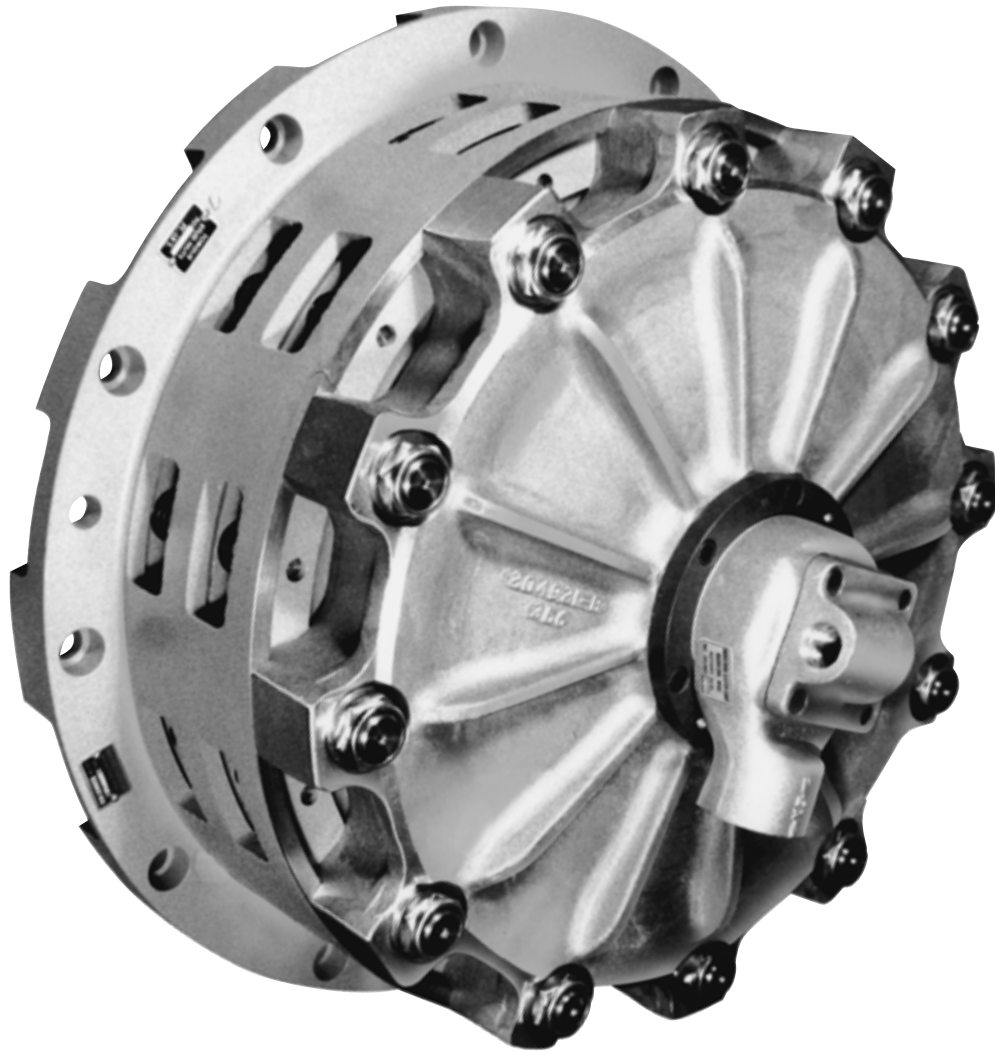

**MODEL LK**

*Air Set Clutches & Brakes*

# LK Clutch or Brake Design Features

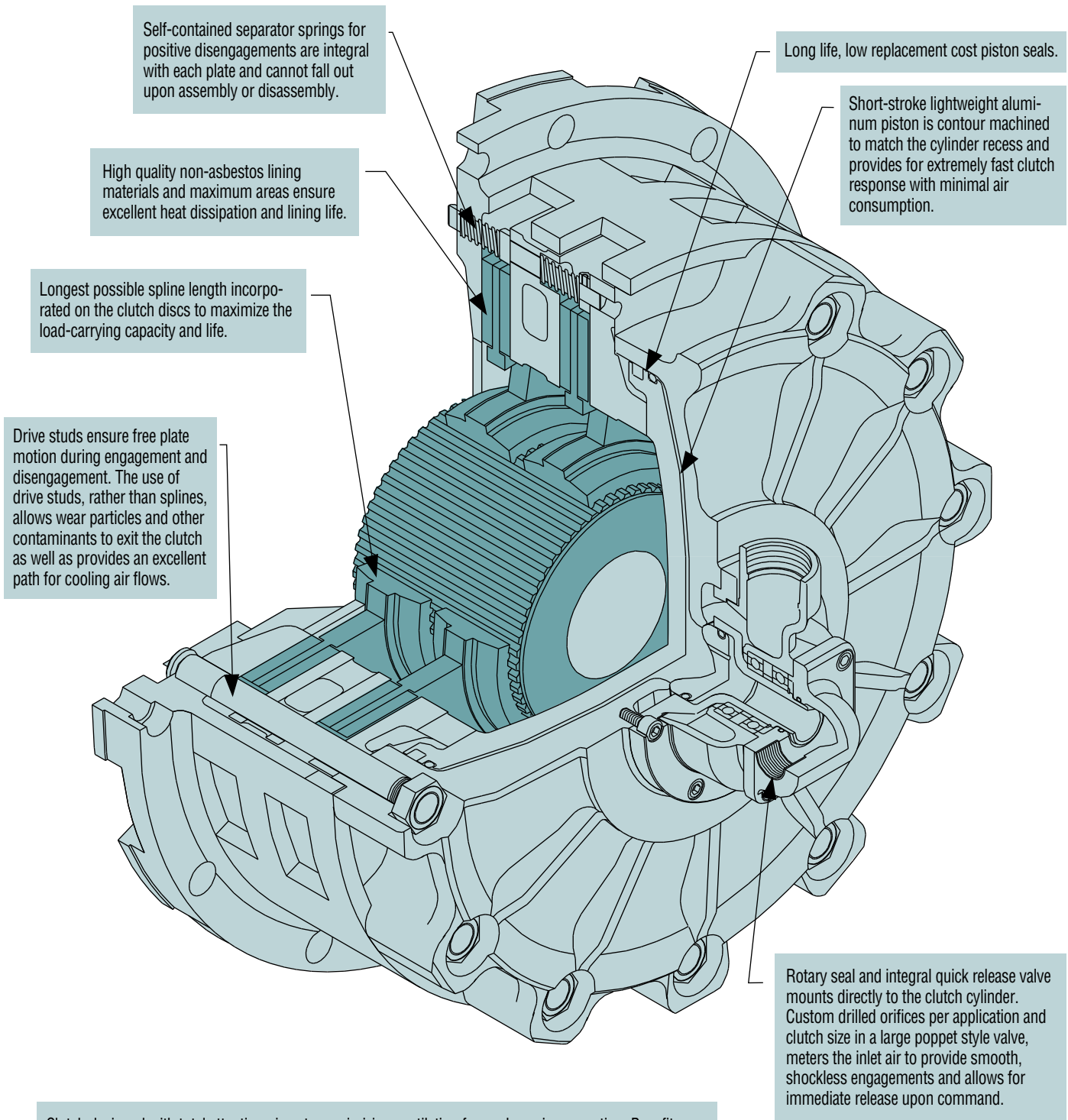

Clutch designed with total attention given to maximizing ventilation for cool running operation. Benefits include: longer lining life; stable friction coefficients; and lower maintenance costs.

All materials selected and field proven to provide the best available resistance to wear and thermal distress.

Precision machining of all components ensures positive interchangeability of all mating parts.

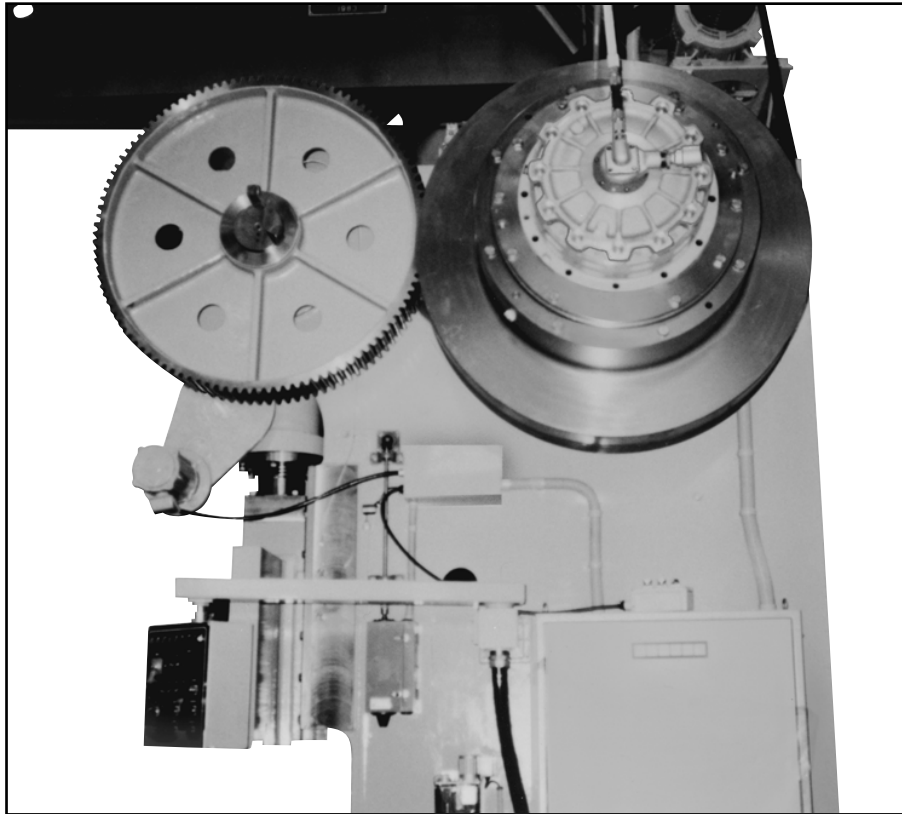

***LK-217 Clutch  
installed on  
200-ton press***

Photo courtesy of Kansai Iron and Sunny Ltd.

### **LOW INERTIA LK CLUTCH OR BRAKE DESCRIPTION**

The Model LK clutch and brake has evolved over many years as a perfect choice for applications requiring rugged and efficient clutching and braking of tough and unusual type loads. The design incorporates an extremely low driven inertia, highest torque capacity per envelope size, and the quickest response with minimal air consumption of any clutch or brake available. It is particularly suited to those applications requiring frequent cycling and long life such as is found in metal-forming or indexing applications.

The components are arranged simply and efficiently.

- A. Drive ring with integral drive studs.
- B. Lined friction discs with internal drive splines.
- C. Driving center plate with integral separating springs.
- D. Driving pressure plate with integral separating springs.
- E. Actuating piston and seals.
- F. Actuating cylinder with integral rotary seal and QRV.
- G. Externally splined inner hub (not shown).

Whether the application is in metalforming, oilfield machinery, cranes, or shovels, the LK low inertia design is an ideal choice for end of shaft mounting arrangements.

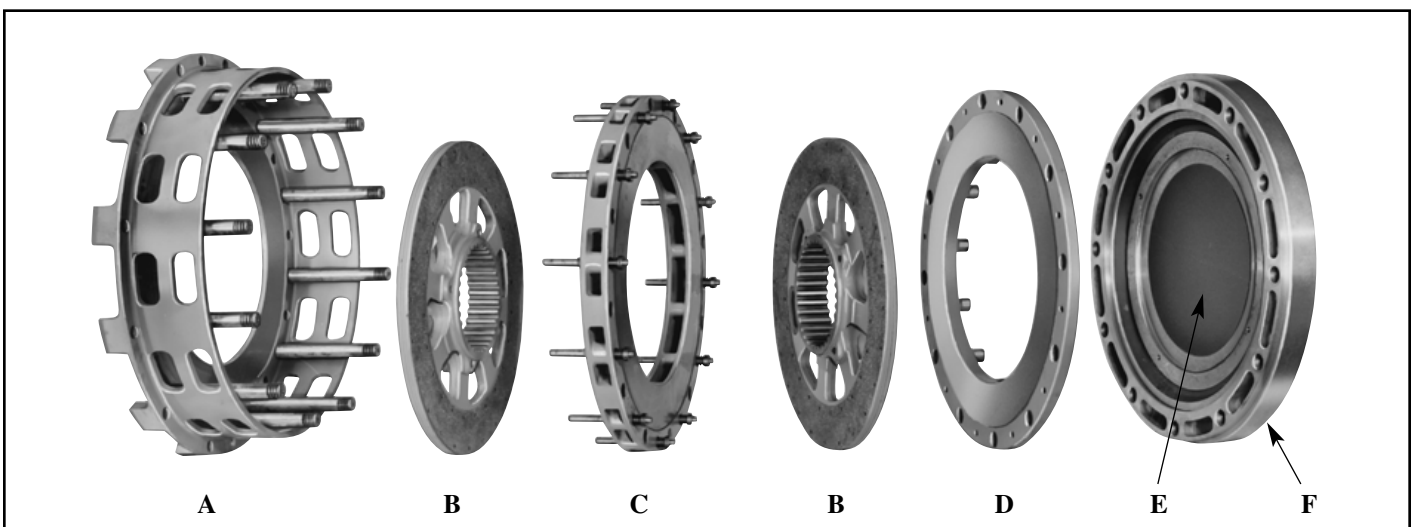

# Model LK

## SINGLE DISC CLUTCH WITH ROTARY SEAL ADAPTOR PLATE

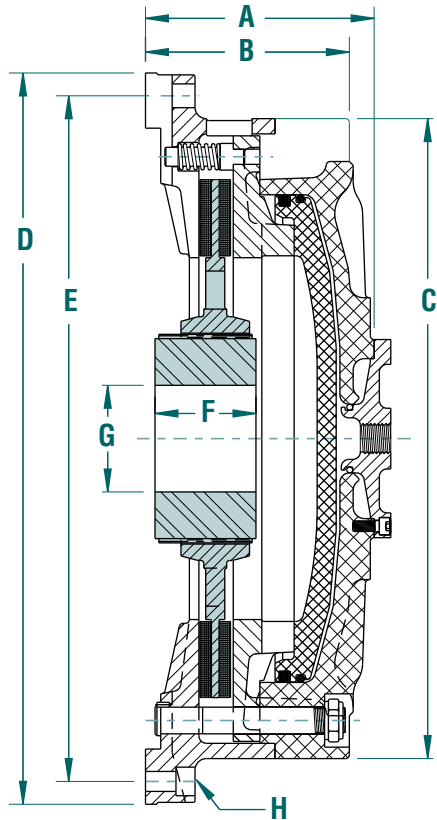

## DOUBLE DISC CLUTCH WITH ROTARY SEAL AND QRV ASSEMBLY

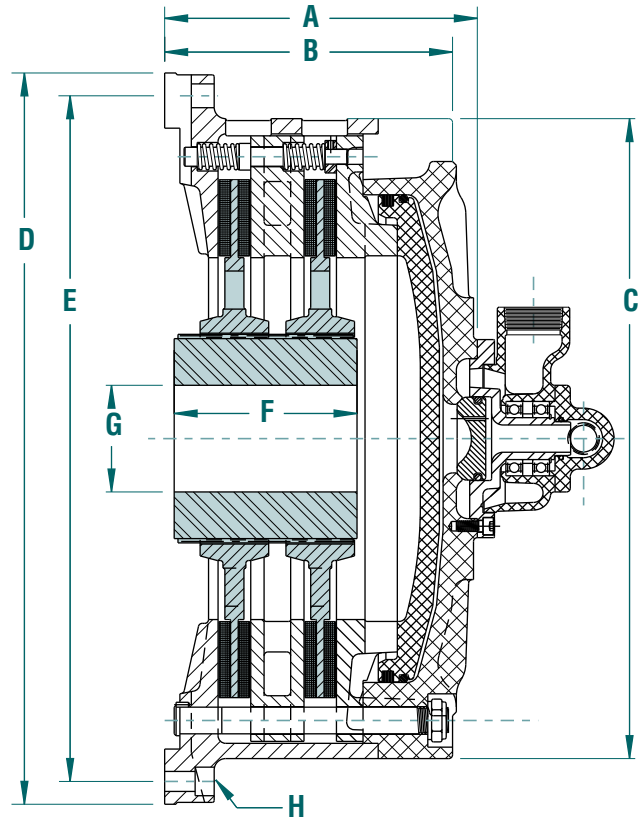

### DIMENSIONAL DATA

All dimensions in inches

LK Model	Static Torque @ 100 PSIG (lb.-in.)	Dynamic Torque @ 100 PSIG (lb.-in.)	Weight Outer (lbs.)	Weight Inner (lbs.)	Total Weight (lbs.)	WR <sup>2</sup> Outer (lb.-ft. <sup>2</sup> )	WR <sup>2</sup> Inner (lb.-ft. <sup>2</sup> )	A	B	C	D	E	F	G Min.-Max.	H No.-Size
LK-108	9,890	8,570	35	7	42	4.55	.20	4.75	3.75	10.50	12.25	11.250	2.25	1-1/8 - 2	8 - 3/8
LK-208	19,780	17,140	49	13	62	6.96	.37	6.38	5.38	10.50	12.25	11.250	3.44	1-1/8 - 2	8 - 3/8
LK-110	17,070	14,800	47	10	57	9.30	.60	4.91	4.25	12.13	14.25	13.000	2.25	1-1/8 - 2	8 - 3/8
LK-210	34,140	29,590	66	12	78	12.17	1.15	6.72	6.06	12.13	14.25	13.000	4.13	1-1/8 - 2	8 - 3/8
LK-111	27,730	24,030	65	13	78	15.74	.98	5.63	4.69	14.25	16.50	15.250	2.75	1-1/8 - 2-3/4	8 - 1/2
LK-211	55,460	48,065	84	28	112	20.29	1.95	7.25	6.31	14.25	16.50	15.250	4.38	1-3/4 - 2-3/4	8 - 1/2
LK-113	48,375	41,925	111	35	146	44.88	2.06	6.63	5.81	16.63	18.88	17.625	3.75	2-1/2 - 3-3/4	8 - 5/8
LK-213	96,750	83,850	140	52	192	57.70	3.77	8.44	7.63	16.63	18.88	17.625	4.50	2 - 3-3/4	8 - 5/8
LK-117	86,400	74,880	185	58	243	96.61	9.35	7.50	6.69	21.00	24.00	22.500	3.31	2-3/8 - 4-1/2	12 - 5/8
LK-217	172,800	149,760	275	111	386	141.06	18.32	10.25	9.44	21.00	24.00	22.500	6.00	2-5/16 - 4-1/2	12 - 5/8
LK-118	106,340	92,160	246	63	309	162.63	10.88	7.68	6.31	22.63	26.25	24.500	3.31	2-3/8 - 4-1/2	12 - 3/4
LK-218	212,680	184,320	353	121	474	223.26	21.50	10.50	9.13	22.63	26.25	24.500	6.00	2-5/16 - 4-1/2	12 - 3/4
LK-121	168,800	146,300	232	72	304	189.40	18.35	7.63	6.63	25.00	28.25	26.750	3.31	2-3/8 - 4-1/2	12 - 3/4
LK-221	337,600	292,590	348	139	487	271.44	36.32	10.19	9.19	25.00	28.25	26.750	6.00	2-5/16 - 4-1/2	12 - 3/4
LK-321	506,400	438,880	363	207	570	353.48	54.33	12.75	11.75	25.00	28.25	26.750	8.75	2-7/16 - 4-1/2	12 - 3/4
LK-125	292,000	253,070	388	131	519	418.0	38.8	9.19	7.50	29.75	32.50	31.000	5.00	3-3/4 - 5-3/8	12 - 3/4
LK-225	584,000	506,130	540	226	766	580.8	74.9	12.38	10.69	29.75	32.50	31.000	7.25	3-3/4 - 5-3/8	12 - 3/4
LK-325	876,000	759,200	634	331	965	745.0	111.8	15.53	13.84	29.75	32.50	31.000	10.25	3-3/4 - 5-3/4	12 - 3/4
LK-130	514,880	446,230	789	211	1,000	1,050.0	90	12.88	9.75	35.50	39.00	37.000	5.00	4-5/8 - 7-1/2	12 - 7/8
LK-230	1,029,760	892,460	1,018	356	1,374	1,384.0	172	16.13	13.00	35.50	39.00	37.000	7.13	4-5/8 - 7-1/2	12 - 7/8
LK-330	1,544,600	1,338,650	1,226	526	1,752	1,722.0	257	19.38	16.25	35.50	39.00	37.000	10.38	4-5/8 - 7-1/2	12 - 5/8
LK-235	1,640,400	1,421,680	1,071	517	1,588	2,053.0	327	13.75	10.48	40.00	39.25	36.375	7.13	5-1/8 - 9-5/8	24 - 1-1/32
LK-335	2,460,600	2,132,520	1,168	732	1,900	2,446.0	483	16.19	12.91	40.00	39.25	36.375	9.56	5-1/8 - 9-5/8	24 - 1-1/32
LK-242	2,851,750	2,471,515	2,749	1,015	3,764	7,473.0	954	18.27	16.58	48.75	48.00	44.000	8.50	6-1/2 - 12	24 - 1-3/4
LK-342	4,277,625	3,707,275	3,286	1,497	4,783	9,145.0	1,422	22.13	20.44	48.75	48.00	44.000	12.31	6-1/2 - 12	24 - 1-3/4
LK-248	4,333,200	3,755,440	3,849	1,420	5,269	13,013.0	1,688	20.45	18.77	54.75	54.00	50.000	9.50	8 - 14	24 - 1-3/4
LK-348	6,499,800	5,633,160	4,628	2,110	6,738	15,954.0	2,522	24.93	23.25	54.75	54.00	50.000	14.00	8 - 14	24 - 1-3/4
LK-448	8,666,400	7,510,880	5,407	2,800	8,207	18,895.0	3,357	29.41	27.73	54.75	54.00	50.000	18.50	8 - 14	24 - 1-3/4

NOTES: 1.) Use certified drawing dimensions only for final layouts.  
2.) DXF and IGES files available upon request.

3.) Dimensions subject to change without notice.

4.) Consult factory or refer to application information when selecting units.